

Model 820 Voltmeter Measurement Applications

Overview

The Trek Model 820 is an ultrahigh input impedance voltmeter that can perform contacting measurements without disturbing the surface charge and potential of an object under test. The convenient hand-held probe enables electrostatic measurement testing using a contacting measurement procedure.

Unlike non-contacting electrostatic voltmeters where there is no physical contact between the test sample and the voltmeter, and therefore, no charge transfer to/from the sample, contacting measurement technology always requires consideration of charge transfer issues. An ideal voltage measuring instrument has the challenge of measuring the voltage of a sample without altering the charge/voltage of the sample; the Model 820 voltmeter meets that challenge.

For example, if an ordinary voltmeter is used to measure the charge associated with a pin of an IC chip, when the instrument makes contact with the pin, all of the charge associated initially with this pin will be removed. As a result, the voltage indicated would be erroneous (the voltmeter will indicate 0 volts). However, the Model 820 can measure the pin voltage without discharging or affecting its voltage.



Figure 1: IC Pin Voltage Measurement

Specification Highlights

- Measurement: Up to ± 2 kV
 - Resistance: Greater than 10^{15} ohms
 - Capacitance: Less than 10^{-15} F
 - Large Signal Bandwidth (-3db): DC to greater than 200 Hz
 - Speed of Response (10 to 90%): Less than 500 μ s for 1 kV input step
 - Noise: Less than 10 mV rms
-
- The measurement probe utilizes a ceramic tip of 0.8 mm diameter (standard with the unit). Highly suitable for precise measurements, these tips, due to their high impedance, do not cause any ESD (Electrostatic Discharge) events during contact with the sample under test even if the voltage of the sample is above the measurement range of the voltmeter. The tips can be customized in various sizes as small as 100 μ m to cater to specific applications.

Fields of Application

- **Measurement of nonlinear surface charge distribution:** When surface charge distribution is nonlinear, as in the case of semiconducting or dielectric materials, the Model 820 contacting type voltmeter is quite useful. For site-specific measurements, non-contacting measurements suffer from spatial resolution limitations; that is, the charge measurement is dependent on the area seen by the probe which includes fringing areas. This can lead to imprecise measurements if the charge distribution is not uniform. The use of the Model 820 resolves this issue by providing measurement of only that area contacted by the probe.

- Voltage monitoring of ESD-sensitive devices:** ESD events can be caused by charge build-up via tribocharging. Prevention of large charge build-up and/or safe dissipation of any charge build-up are the only means to control ESD. In the semiconductor industry, devices fail due to ESD during handling and processing. The Model 820 contacting measurement technology helps in measuring voltage precisely on ESD-sensitive devices such as semiconductor chips and MR head sensors.
- Scanning applications:** By utilizing the tip specifically designed for non-contacting measurements, the Model 820 can be utilized to scan surface materials to determine the charge distribution on the material. Due to very low drift (less than 6 V per minute) and high bandwidth capability, a scan of large surfaces is possible. The special RESET function allows the "restoration" of a zero voltage level by actuation of the RESET function while the probe is positioned over a known zero level on the scanned surface.

Figure 2 shows a probe tip that can be used for scanning purposes. Figure 3 shows a test plate with strips alternately connected to a voltage source and ground. The probe was mounted at a distance of 500 μm from the plates. The voltage monitor output of the unit was connected to an oscilloscope. The waveform of the voltage measured by the voltmeter when the probe scanned the test plate from left to right is shown.



Figure 2: Probe Tip

Resolution Plate

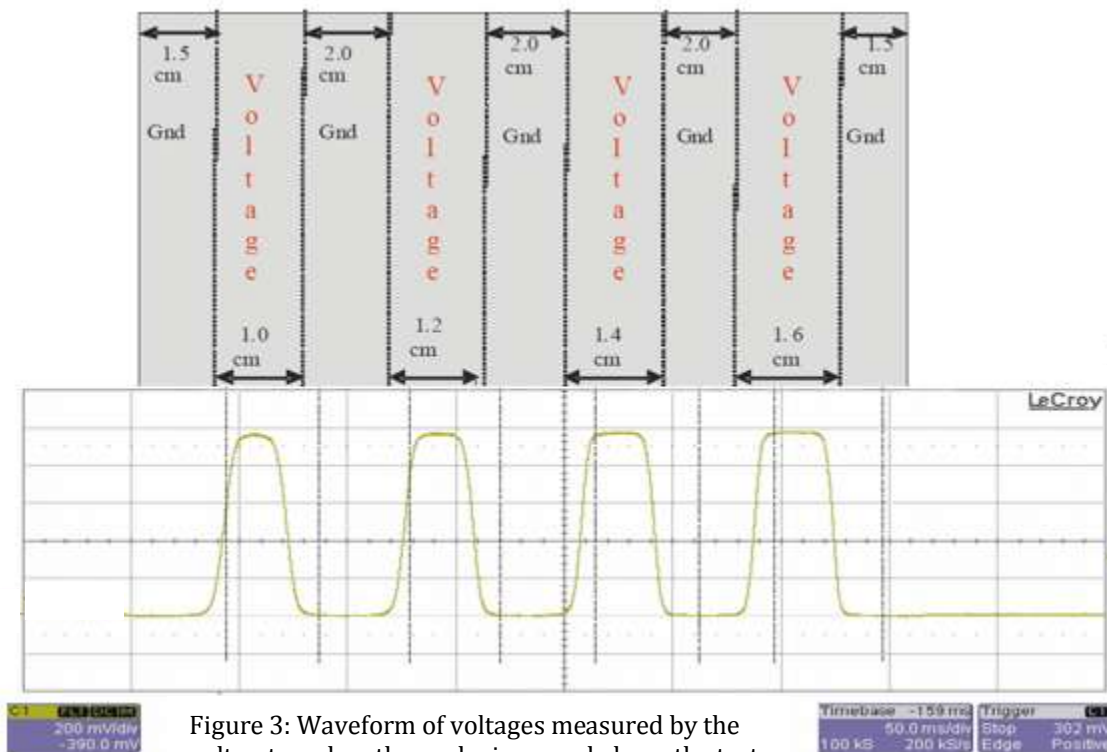

Figure 3: Waveform of voltages measured by the voltmeter when the probe is moved above the test plate in a non-contacting manner

Other Applications

Other applications that could benefit from the Model 820 contacting measurement technology include:

- Powder handling (chemical, pharmaceutical, ceramic and other materials)
- Electrostatic painting/coating
- Electrostatic potentials on film, polymers, and paper
- Test and measurement, instrumentation
- Material evaluation
- Quality control
- Automotive, aerospace
- R&D applications

Measured Voltage vs. Charge

The measured voltage level of charged surfaces/objects relative to a reference surface is an indication of the charge levels of the surface/object, but only if the capacitance between the surface/object and reference surface is known. In the example of Figure 4 below, two dielectric material blocks, 1 and 2, have their top surfaces charged to equal charge levels, Q . The capacitance between the charged top surfaces and the ground reference surface R is $C = KA/D$, where C is the capacitance, K is a constant related to the permittivity ϵ of the dielectric material of the blocks, A is the top surface area and D is the distance between the top surface and reference surface, R .

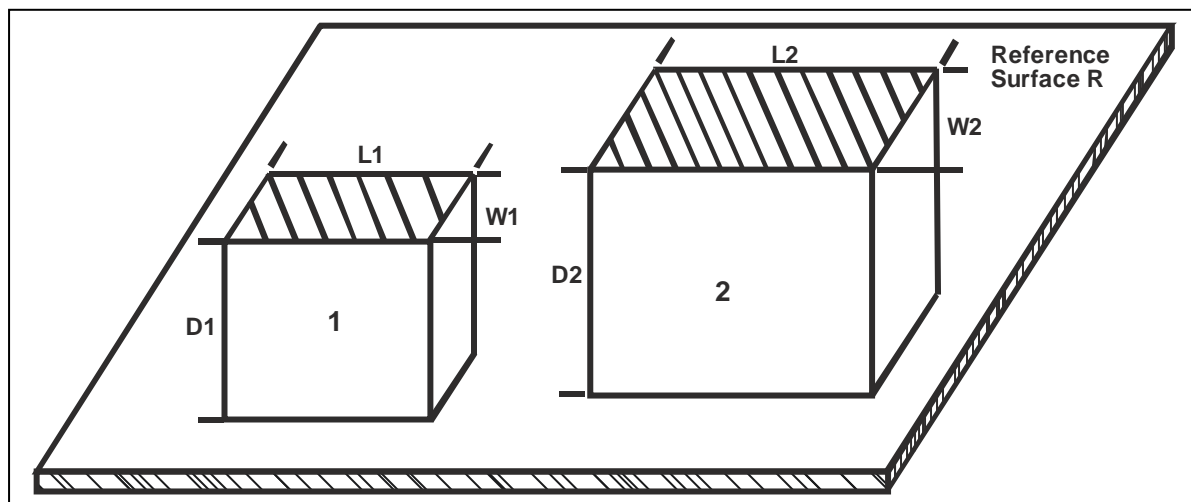

Figure 4: Measured Voltage vs. Charge

If the area A of the top surfaces of the blocks is equal, i.e. $L1 \times W1 = L2 \times W2$, and ϵ , the permittivity of the dielectric material of both blocks is the same, the ratio of the capacitance $C1$ to $C2$ is equal to $(K1/D1) / (K2/D2) = D2/D1$ (where $K1 = \epsilon A = K2$).

Using $V1 = Q/C1$ and $V2 = Q/C2$, where $V1$ and $V2$ are the voltage levels of the top surfaces of blocks 1 and 2 respectively, relative to the grounded reference surface R , and Q is an equal charge added to each top surface, the ratio of $V1$ to $V2 = C2/C1$. Therefore, for any equal charge level on surfaces/objects, the measured voltage level will depend upon the capacitance of those surfaces/ objects relative to a reference surface.

The advantage of using the Trek Model 820, either in a contacting or non-contacting mode is that the capacitance normally added by other voltage monitoring devices/systems — which would change the measured voltage by changing the capacitance of the surface/object — is completely avoided by using the Model 820 due to its virtually zero input capacitance.

Measurement Tips

- If an extraneous charge is accumulated on the input capacitance of the probe, thereby causing the voltmeter to indicate some voltage level, this charge should be removed before performing the next measurement. This can be done by placing the probe in the probe holder (see Figure 5) and activating the RESET function.

Another way to remove any extraneous charge from the voltmeter input capacitance is to touch the probe tip to the blue circle area (zero pad) on the holding fixture which is referenced to the voltmeter's ground. This will remove the extraneous charge without utilizing the RESET function. Touching the zero pad with the point of the probe should be performed between each succeeding measurement.

- Avoid "rubbing" the probe tip (the probe tip is made from a semiconducting ceramic) on the surface being measured to prevent tribocharging of the tip's material and thereby placing a charge on the input capacitance of the probe. Due to the input capacitance being infinitely small, even a very small tribocharge will cause high voltage to be read by the voltmeter.
- Keep the probe in the probe holder when not in use to prevent the probe tip from being accidentally damaged.

It is interesting to note that during normal operation, when using the hand-held probe, as the probe approaches the surface being measured, the Model 820 will indicate the voltage level of the measured surface even before actual contact is made. This occurs due to the virtual zero input capacitance of the probe in relation to the high capacitive coupling between the probe and test surfaces just before contact is made.



Figure 5: Probe holder shown at right