

The Electrostatic Semiconductor Wafer Clamping/Chucking System (ESC)

The electrostatic chuck (ESC) is used in a variety of semiconductor processes to hold the wafer during processing. ESCs employ a platen with integral electrodes which are biased with high voltage to establish an electrostatic holding force between the platen and wafer, thereby “chucking” the wafer.

Presently most process tool manufacturers use low speed DC signals to control high voltage power supplies. This allows them to control the voltage set-points and sequencing of the clamp and de-clamp functions of the ESC. While this provides basic ESC operation, the technique limits the complexity of the bias signals that can be applied to the ESC. In order to provide greater waveform sophistication, Trek has incorporated a microprocessor-controlled arbitrary waveform generator in combination with a high speed, high voltage amplifier and Electrostatic Voltmeter so that a wide range of clamp sequences may be generated and monitored in order to optimize performance of the clamping and de-clamping process by controlling the ramp, overshoot and duration of the HV signal

Several process tool companies have begun to use Trek HV amplifiers in conjunction their own signal generators to produce more advanced ESC waveforms to drive their platens. Building upon this technique, Trek has advanced the technology further by offering a complete solution for generation, high voltage and wafer monitoring, all in a single instrument. This makes it easy to produce waveforms which have tailored risetime, controlled overshoot, adjustable bias and sophisticated trailing edge shape.

This system allows optimization of the electrostatic force profile needed to provide effective ESC operation for each wafer/platen application. As effective ESC operation must address issues of minimum clamping time, variation in clamping force during the wafer processing, as well as wafer charging control to minimize wafer “sticking” to the platen, etc.

Trek’s marriage of high voltage amplifier technology and arbitrary waveform generation provides the semiconductor tool manufacturer with a new way to control the electrostatic chuck with better clamping, more efficient de-clamp and minimum residual wafer charge. Trek provides a development system and a production driver in an easy to use configuration with numerous features available for the first time.



Figure 1. Trek Model 640 Electrostatic Chuck Optimizer



Figure 2. Trek Model 645. Production Electrostatic Chuck Driver

Many end users regard the design of an electrostatic chuck as a black art. End users blame process errors on the design implementation of the ESC so having the flexibility to create diverse waveforms will be a strategic advantage to the process tool manufacturer. Also, as line widths shrink below the present 45 nm state of the art, damage in processing due to electrostatic discharge (ESD) becomes a serious issue. Again, the ability to tailor the shape of the falling edge of the ESC waveforms minimizes the possibility of ESD and makes the product more attractive for next generation processing.

ESC Optimization and Control – A new approach to allow for optimization and control of the ESC voltage waveform/profile at the system designer/user level is provided by Trek through the introduction of a new method and product family. The new family utilizes Arbitrary HV Waveform Generation technology and provides both a development system called an ESC Optimizer (Trek 640) and a production Chuck Driver (Trek 645) having the required functionality as developed through use of the 640 Optimizer by the ESC system designer/user for a particular platen and process.

The Optimizer provides hardware and software to allow the ESC system tool manufacturer to quickly and easily develop and evaluate the clamping performance achieved using his own custom waveforms. The production driver instrument is a compact device that accepts a download of the optimized high voltage waveforms program and helps to bring a new tool online quickly and easily with no surprises in the performance of the electrostatic chuck. The two products are shown in Figures 1 and 2. They are discussed in detail below.

Arbitrary HV Waveform Technology – The Trek models 640 and 645 both utilize arbitrary waveform generator (AWG) technology using easy-to-use software to allow various waveforms to be created and evaluated by the user. When the AWG is coupled to a HV amplifier, an ESC driver with unprecedented performance results.

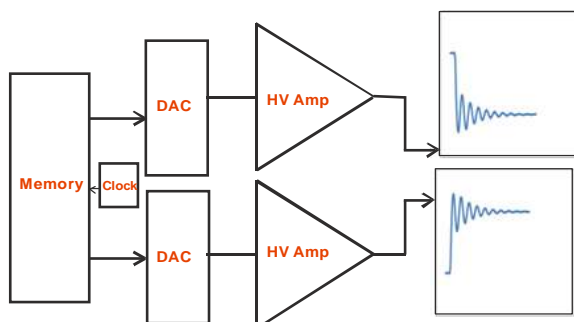

Figure 3. The arbitrary waveform generator and the high voltage amplifier working together

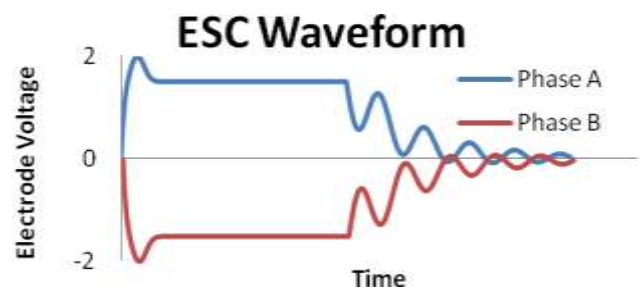

Figure 4. A pair of waveforms useful for ESC applications.

The Trek ESC software and hardware allows the user to easily create waveform files with Excel or by using Trek's waveform generation software. The resultant waveform files are converted to analog signals and amplified by Trek HV amplifiers in the ESC driver instrument. See Figure 3. Virtually any waveforms are possible. To illustrate the utility of this technology, a very useful waveform for the application is shown in Figure 4. The waveform in Figure 4 has intentional overshoot to pull the wafer in firmly and an oscillatory tail intended to minimize any residual charge that might otherwise remain on the wafer after the process is complete. Note that an ESC

driver circuit using simple high voltage supplies could not produce waveforms like those in Figure 4.

Advanced Software – Optimization of the ESC performance involves evaluating a variety of waveforms by the design engineer. The Trek 640 and 645 both offer easy-to-use software allowing the user to build waveforms quickly and easily. This is done by creating them using Excel or by drawing them using a mouse. As shown in Figure 5, the software for the Trek 640 breaks the ESC waveform into three segments called **Clamp**, **Process** and **De-Clamp**. These segments are executed seamlessly by virtue of the architecture of the arbitrary waveform generator. A library of segments can be created to make the optimization process convenient. The software also handles the gain factor and thus converts vertical units to kilovolts automatically. Once the correct three segments are indentified in the 640 system, a composite waveform can be built and loaded into the Trek 645.

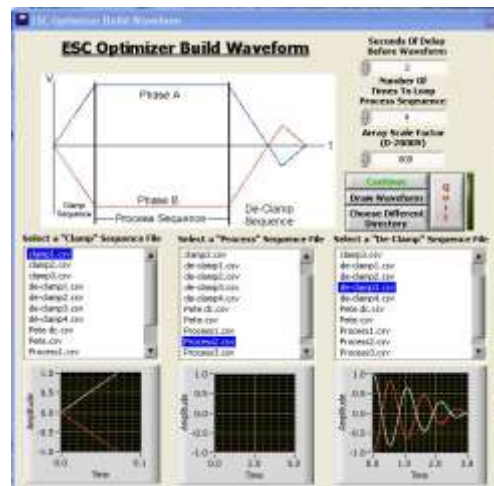

Figure 5. A screen shot of the Chuck Optimizer software with three segments selected.

For the Trek 640, waveforms are stored in the host PC and data are streamed to the instrument over the USB. For the 645, waveforms are stored in the instrument itself in non-volatile RAM. These are logical architectures since the Trek 640 is a computer-based development system but the 645 is intended to stand-alone in the process tool without need for computer intervention for tool operation.

Bias Voltage Offset - One of the effects of the plasma in a process chamber is to create a voltage offset at the ESC. This voltage in conjunction with the electrode voltage changes the potential difference across the chuck and can cause a discharge across the chuck dielectric or to the wafer itself. Either can result in damage. To account for this offset, ESC designers apply a bias voltage to each of the chuck electrode signals during the time that the plasma is present. This adds to one phase and subtracts from the other phase. See Figure 6. The user can program the amount of bias voltage for both polarities and an externally applied signal determines when the bias voltage features is active. In the Trek 645, the bias is added to the waveforms using the AWG function.

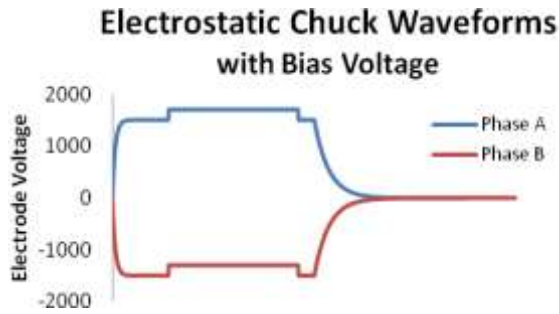

Figure 6. Application of a bias voltage.

Unique Wafer Sensor – One novel feature of the Trek ESC system is the use of a technique which detects the presence of and the status of the wafer on the platen. By superimposing a small (~10V) AC signal to the DC level during the processing time interval, C_{cw} , the chuck-wafer capacitance can be measured. The result of the measurement, indicates wafer presence on the platen and if the wafer is successfully clamped. Both Trek ESC driver products provide this information at the front panel and also to the host PC via the communication port. The front panel display of the Trek 645 is shown in Figure 7. The display shows both the measured capacitance and interprets it as; wafer not present; wafer present; but not clamped and wafer clamped.



Figure 7. Display of the wafer status on the ESC.

Electrostatic Voltmeter Technology – One of the issues of concern for an ESC is the amount of residual charge left on the wafer after processing. The presence of high voltage and charge carriers associated with the plasma or ion beam process can easily leave the surface of the wafer charged. Further, if there is dielectric on the wafer being processed, surface charge will be trapped even if the wafer is grounded. Residual charge can result in increased wafer release time, wafer damage through electrostatic discharge and an increase of micro-contamination levels due to electrostatic attraction. For these reasons, it is necessary to design a wafer chucking system which leaves the wafer close to neutral after processing.

Determining the voltage level on the wafer is not simple. The input impedance of a conventional voltmeter will discharge the wafer so the measurement will erroneously indicate an uncharged wafer. An ultra-high impedance electrostatic voltmeter is required to make this measurement. Trek provides a family of electrostatic voltmeters which measure the voltage of objects and surfaces by capacitively coupling to the object in a non-contacting manner. A Trek non-contacting electrostatic voltmeter is included in the Trek 640 Optimizer to allow accurate measurement of the wafer voltage.

It is normally impractical to install the voltage sensor at the platen processing in the chamber, however, a direct view must be provided to use the voltmeter. One approach is to place a contact inside of the process chamber near the underside of the wafer with an electrical connection brought out through an insulating vacuum feed-through. Then with the wire terminated in a small metal plate, the voltage on the plate will be equal to the voltage on the wafer and the electrostatic voltmeter can be used to measure that voltage level. See Figure 8. Alternatively it may be possible to use the wafer lifting pins as part of the voltage measuring system. See Figure 9.

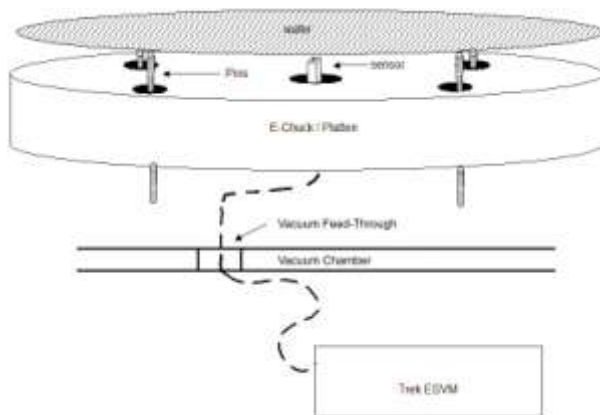

Figure 8. Measuring the voltage on a wafer through near contact with the wafer

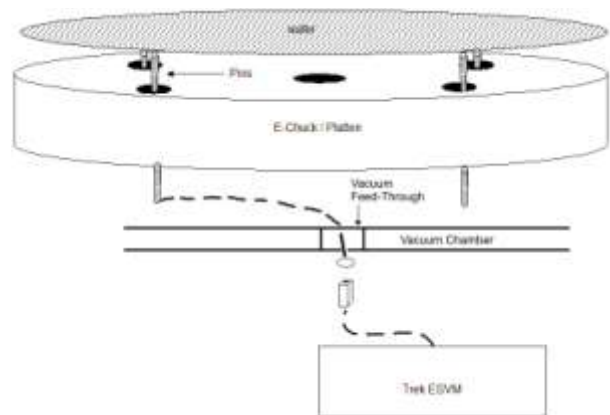

Figure 9. Measuring wafer voltage through a lift pin.

Additional Important Features of High Voltage Amplifiers – As with all high quality HV amplifier products, the Trek ESC system provides current and voltage monitoring to provide operational information. Also, for safe operation, Trek amplifiers provide current limiting circuitry. By automatically limiting current, the chuck driver can avoid damaging the tool components in the case of a high voltage breakdown. The block diagram of the ESC system including the monitors and current limit is shown in Figure 10. The electrostatic voltmeter shown in the diagram is only included, as standard, with the Trek 640.

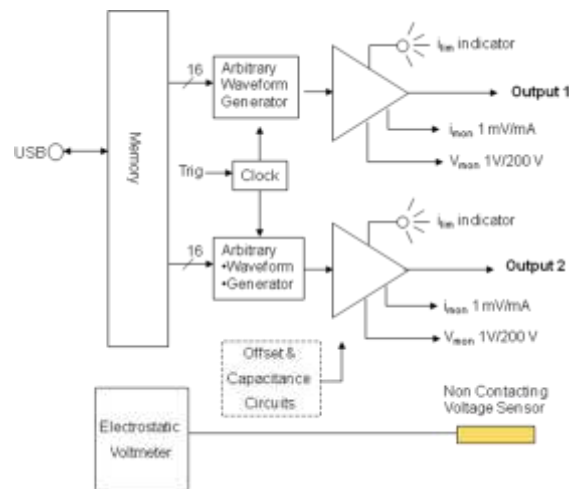

Figure 10. Typical block diagram of the Trek electrostatic Chucking Amplifier products

Summary – Often a major technological advance results from the marriage of several technologies that were not previously used together. The modern automobile navigation system is an example of such an advance. The GPS, puzzle solving software and voice synthesis were brought together to create the navigation system, creating an entirely new technology from existing technologies. The Trek ESC driver also falls into this category. AWG technology and HV amplifier technology are not new but they do bring more ESC performance when used together. By optimizing the wave shape, better adhesion, optimized bias compensation and minimum charging can be achieved. By providing both an Optimizer product with all of the bells and whistles needed for easy waveform editing and system metrology and a separate minimum footprint unit which accepts the waveforms developed in the Optimizer system, a new tool can be efficiently brought online in a minimum amount of time, thus contributing favorably to a reduced time to market of the product.



Some Specifications for the ESC System. For full detail, see the complete data sheet at <http://www.trekinc.com/products/640.asp>.

PERFORMANCE (EACH PHASE)

Phase A Output Voltage Range

0 to ± 2 kV DC or peak AC (4 kV p-p).

Phase A Output Current Range

0 to ± 5 mA DC or peak AC (10 mA p-p).

Phase B Output Voltage Range

0 to ± 2 kV DC or peak AC (4 kV p-p).

Phase B Output Current Range

0 to ± 5 mA DC or peak AC (10 mA p-p).

PERFORMANCE (EACH PHASE)

Large Signal Bandwidth (1% distortion)

DC to greater than 1.2 kHz.

Small Signal Bandwidth (-3 dB)

DC to greater than 5 kHz.

Slew Rate (10% to 90%, typical)

Greater than 15 V/ms.

Settling Time (to 1%)

Less than 300 ms for 0 to 2 kV step.

DC Accuracy

Better than 0.1% of full scale.

Offset Voltage

Less than 500 mV.

Output Noise

Less than 100 mV rms (measured using the true rms feature of the Hewlett Packard Model 34401A digital multimeter).

Drift with Time

Less than 100 ppm/hour, noncumulative.

Drift with Temperature

Less than 350 ppm/ $^{\circ}$ C.

PRODUCT FEATURES (EACH PHASE)

Front Panel Display

A $3\frac{1}{2}$ digit LED display.

Voltage Range

0 to ± 1999 V.

Voltage Resolution

1 V.

Zero Offset

± 1 count, referred to the voltage monitor. **Voltage Monitor**

A buffered output providing a low-voltage representation of the high voltage output.

Scale Factor

1 V/200 V.

DC Accuracy

Better than 0.1% of full scale. (May degrade to 0.6% in the presence of RF fields up to 3 V/m.)

Offset Voltage

Less than 5 mV.

Output Noise

Less than 10 mV rms (measured using the true rms feature of the Hewlett Packard Model 34401A digital multimeter).

Output Impedance

Less than 0.1 ohms.

Current Monitor

A buffered output providing a low-voltage representation of the load current.

Scale Factor

1 V/mA.

DC Accuracy

Better than 1% of full scale.

Offset Voltage

Less than 5 mV.

Output Noise

Less than 10 mV rms (measured using the true rms feature of the Hewlett Packard Model 34401A digital multimeter).

Bandwidth (-3db)

DC to greater than 800 Hz.

Output Impedance

Less than 0.1 ohms.

WAVEFORM GENERATOR

0 to ± 2 kV DC or peak AC

Measurement Accuracy at the Voltage Monitor

Better than $\pm 0.05\%$ of full scale.

Measurement Accuracy at the Voltage Display

Better than $\pm 0.1\%$ of full scale ± 1 count, referred to the voltage monitor.

Speed of Response (10% to 90%)

Less than 100 μ s for a 1 kV step.



TREK, INC. 190 Walnut Street • Lockport, NY 14094 • 800-FOR TREK
716-438-7555 • 716-201-1804 (fax) • www.trekinc.com • sales@trekinc.com

